

**Statement by the School Bus Information Council
Carpenter School Buses
July 1, 2003**

The National Highway Traffic Safety Administration (NHTSA) has released recommendations to address a safety concern about certain school buses built by Carpenter Manufacturing with broken or cracked welds in the roof structure.

The School Bus Information Council (SBIC) first became involved in this problem last April after a crash in Florida caused us to send our own preliminary safety advisory to all state directors of pupil transportation safety and others in the industry.

The problem is broken or cracked welds in the roof structure that can cause the roof to collapse in the event of a rollover crash. Not all Carpenter buses have the broken or cracked welds. The problem is confined to all types of school buses built at the Carpenter plant in Mitchell, Indiana, prior to its closing in late 1995. SBIC estimates that there could be as many as 15,000 buses affected – just 3 percent of the national school bus fleet – although the actual number may be significantly less since many of the Carpenter school buses built at the Mitchell plant are no longer in service.

Importantly, parents and school officials should know that school buses remain the safest way for children to get to and from school. SBIC is not aware of any injuries or fatalities to students that are associated with this problem with Carpenter school buses. Indeed, fatalities to children riding in school buses are extremely rare.

Because Carpenter Manufacturing is no longer in business, a full-scale safety defect investigation by NHTSA with a probable safety recall to repair the affected buses for free cannot be made. NHTSA has, therefore, recommended these options for Carpenter buses that are found to have cracked or broken welds in the roof structure:

- *The bus should be taken out of service and replaced as soon as possible.* In these instances, NHTSA recommends that the word “scrap” or equivalent language be marked on the vehicle’s title to preclude their sale to unsuspecting purchasers.
- *If the bus must continue in use, the cracked or broken welds should be repaired as soon as possible by qualified service personnel.* In these instances, SBIC believes that certified welders and professional engineers would be appropriate qualified personnel.
- In order to minimize the risk of rollover, the bus should be used on routes that operate in low-speed environments.

These recommendations by NHTSA are the same as were issued by SBIC on April 30, 2003, however, SBIC also advised states and local school districts to:

- Use the affected Carpenter school buses for “reserve” or “back up” service; and

- Not use the affected Carpenter school buses for activity trips.

NHTSA also said, "... each State and school bus operator must assess its own situation and circumstances in deciding what actions to take." Clearly, NHTSA's first recommendation is to replace the Carpenter school buses as soon as possible. If that is not possible or practicable, and a state or school bus operator attempts to make a repair, NHTSA noted that **"given the age and the type of weld failures occurring in these buses, there is no single repair that can assure adequate performance in a crash. Since NHTSA is not the vehicle manufacturer and does not know all of the relevant details about the design and construction of these buses, it cannot recommend any particular modification or repair procedure."**

This guidance from NHTSA clearly indicates that the overall condition of the Carpenter school buses will ultimately contribute to the decision of whether it is possible to attempt a repair to the broken or cracked welds, and if so how to accomplish the repair. These Carpenter school buses have been in service more 8 or more years, and in some instances may have developed rust conditions that could have an effect on any repair attempt.

The SBIC urges states to complete their inspections expeditiously and, following NHTSA's guidance, either replace or thoroughly repair affected buses back to their original condition to ensure that pupil transportation – the safest way for children to get to and from school – is not impeded. As part of the school bus industry's commitment to safety and the environment, SBIC urges school districts that opt to replace their Carpenter school buses to purchase models that have the newest safety equipment and are powered by engines with the latest emission control technology.

School buses meet the toughest safety requirements of any motor vehicle and have the best safety record in the transportation industry. Indeed, the greatest safety risk to children would be if a school district scrapped the affected Carpenter school buses without replacing them immediately. This would force students to get to and from school by riding with parents or friends, or even walking or bicycling – all of which are riskier ways to travel according to a 2002 study by the National Research Council of the National Academies of Science.

The NHTSA advisory follows.

Carpenter School Bus Advisory June 2003

On March 20, 2003 in Alachua County, Florida, an 83-passenger Carpenter school bus rolled over onto its roof, causing the roof to collapse down to the seat level. Inspection of the crash vehicle revealed numerous broken and defective welds in the roof and pillar structure. Normally, the National Highway Traffic Safety Administration would conduct a full-scale investigation and if a defect determination were made, would order the manufacturer to conduct a safety recall. However, since Carpenter is no longer in business, there is no one that NHTSA can hold accountable to develop a remedy for this problem.

However, NHTSA is concerned about this problem. The purpose of this advisory is to provide school districts and school bus operators with guidance on what to do if they have any of these buses within their fleets. Unfortunately, given the age and the type of weld failures occurring in these buses, there is no single repair that can assure adequate performance in a crash. Since NHTSA is not the vehicle manufacturer and does not know all the relevant details about the design and construction of these buses, it cannot recommend any particular modification or repair procedure.

At this time, we strongly encourage owners and operators of the Carpenter school buses described below to inspect them to determine if there are structural weld failures in the roof structure. The welds in question are located at the junction of the vertical side posts (between the windows) and the horizontal structural member (the "Carlin" rail) above the windows. The inspection will require the removal of interior panels as well as the removal of some of the windows. The following information is provided for your consideration and use:

1. The buses in question are Carpenter Type "A" "B" "C" and "D" school buses built in Mitchell, Indiana, prior to the plant closing in late 1995. It appears that the buses built at Carpenter's Richmond, Indiana plant do not have similar problems.
2. There are noticeable differences between the rub rail locations for the two Carpenter plants. The rub rail at the floor line in all buses made at the Mitchell plant is interrupted at the wheel openings. The rub rail at the floor line in all buses made at the Richmond plant is continuous and is located just above the wheel opening. If the 6 digit body number starts with the number 4, then the bus was built in the Richmond, Indiana plant and utilized full length body bows.



Figure 1: Mitchell built type "C"



Figure 2: Richmond built type "C"



Figure 3: Mitchell built type "D"



Figure 4: Richmond built type "D"

3. All Carpenter school buses built in Mitchell, Indiana, no matter what the body number, should be inspected for cracked or broken welds in the roof structure. The photograph below shows the locations of the components that are welded together.

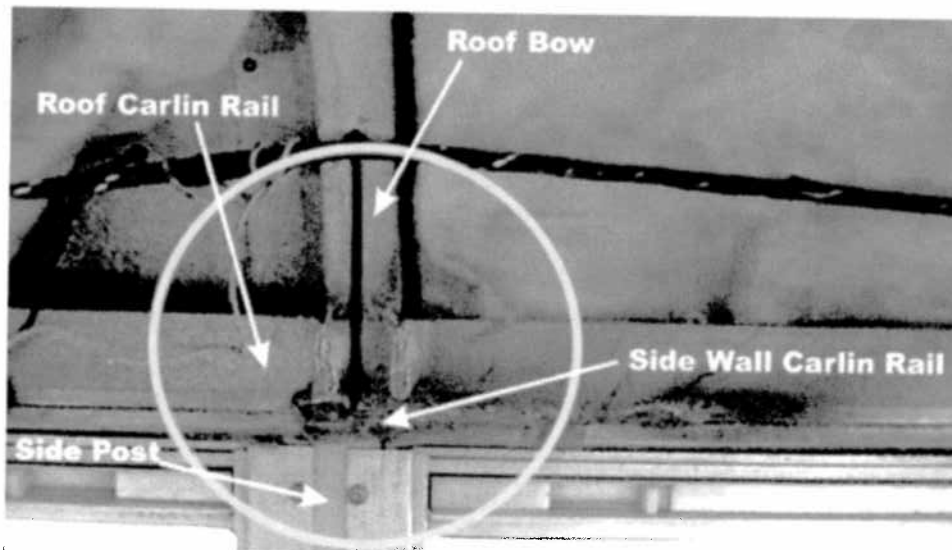

Figure 5: Photo depicting weld locations

4. Two diagrams showing the components and weld locations are shown below:

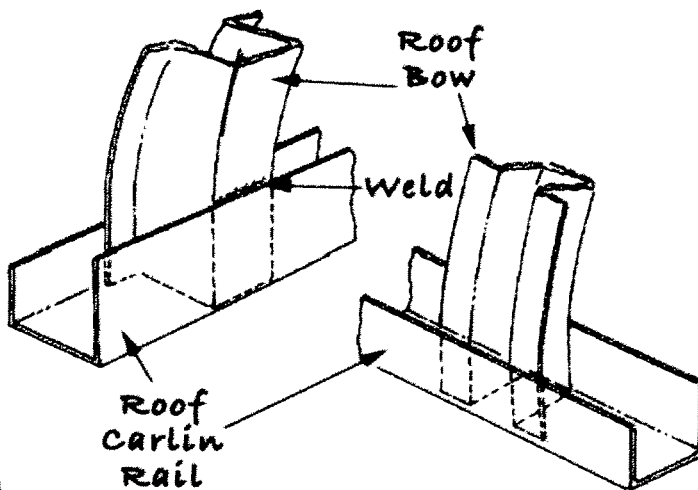

Figure 6: Roof bow weld locations

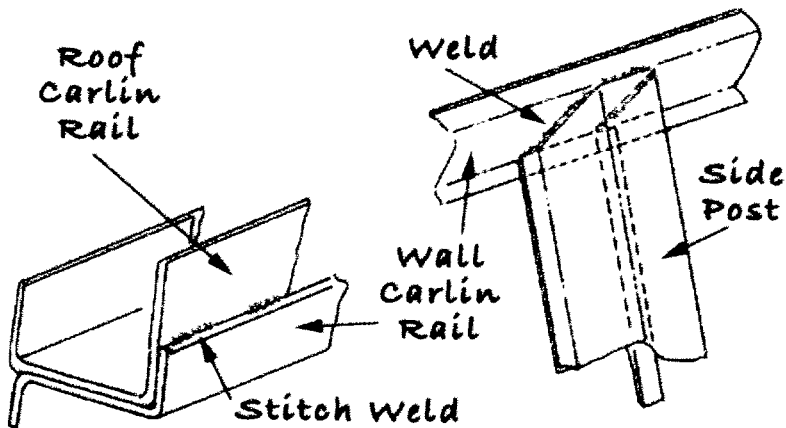

Figure 7: Carlin rail weld locations

Reports received from various states and school districts around the country indicate differences in the extent of the failures. Some reports reveal significant numbers of school buses with numerous cracked or broken welds, while other reports reveal few, if any, cracked or broken welds. Furthermore, in some cases, metal deterioration has occurred. Insufficient data exists to ascertain whether the failures are related to the environment, age, and/or mileage.

NHTSA recommends that the following actions be taken with respect to any Carpenter school bus built in the Mitchell plant that has been found to have cracked or broken welds in the roof structure:

The bus should be taken out of service and replaced as soon as practicable.

If the bus must continue in use, the cracked or broken welds should be repaired as soon as possible by qualified service personnel.

In order to minimize the risk of a rollover, the bus should be used on routes that operate in low speed environments.

Buses that are taken out of service should have “scrap” or equivalent language marked on their titles to preclude their sale to unsuspecting purchasers.

Transportation experts agree that school buses are among the safest of all modes of transportation. Statistics show that children are safer on a school bus than on other modes of transportation. With respect to the Carpenter bus weld problem, each State and school bus operator must assess its own situation and circumstances in deciding what actions to take.

* * * *